

PRODUCT DATASHEET

PANEL INDV EM 600 33 W 4000 K

PANEL IndiviLED EMERGENCY 600 | Square recessed luminaire with IndiviLED optics, self-contained emergency luminaire, 600mm

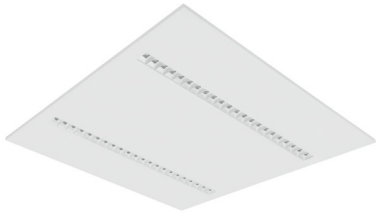

AREAS OF APPLICATION

- Direct replacement for luminaires with fluorescent lamps
- Emergency illumination of escape routes
- Antipanic lighting
- Buildings requiring up to 3 h emergency light operation
- Reception areas, foyers, corridors, elevators
- Offices, conference rooms
- Suitable for recessed ceiling systems with grid size of 600 x 600 mm

PRODUCT BENEFITS

- Homogenous light distribution and reduced glare thanks to the IndiviLED optics
- Seamless integration of luminaires with emergency lighting function into general lighting
- Easy wiring thanks to included prewired driver and battery for Emergency lighting function
- Simple testing of luminaires with emergency lighting function thanks to integrated automatic test function
- Convenient visualization of results of automatic test with an included control LED
- Operation of integrated emergency lighting function with long life LiFePO4 battery with 3h battery discharge time
- Energy savings of up to 50 % (compared to luminaires that use fluorescent lamps)
- Robust structure with IK08
- Low flicker light thanks to special electronic control gear
- 3 years guarantee

PRODUCT FEATURES

- Each LED with individual lens and reflector for UGR<16 and homogenous light distribution
- Luminaire suited for normal lighting and emergency lighting



- Certified according to European norms (EN 60598-1:2015; EN 60598-2-22:2014)
- Self-contained luminaires
- Emergency lighting function: battery discharge time of 3 h
- Function test of emergency lighting: automatic (AT)
- Battery technology: LiFePO4
- Metal housing, polycarbonate (PC) lenses and reflectors
- Luminous efficacy: up to 120 lm/W
- Initial color consistency: 3 SDCM
- Glow Wire Test according to IEC 60695-2-12: 850 °C

TECHNICAL DATA

Electrical data

Nominal wattage	33.00 W
Operating mode	External LED driver
Nominal voltage	220...240 V
Mains frequency	50/60 Hz
Power factor λ	> 0.90
Max. no. of lum. on circuit break. B16 A	58
Max. no. of lum. on circuit break. C10 A	36
Max. no. of lum. on circuit break. C16 A	58
Inrush current	36.4 A
Total harmonic distortion	< 20 %
Wattage in emergency operation mode	3.0 W
Nominal voltage of battery	3.2 V
Wattage in maintained operation mode	33.0 W
Inrush current time T_{h50}	80 μ s

Luminaire control gear data

Low flicker	Yes
-------------	-----

Photometrical data

Color temperature	4000 K
Color rendering index Ra	≥ 80
Light color (designation)	Cool White
Luminous flux	4000 lm
Luminous efficacy	120 lm/W
Standard deviation of color matching	3 sdcM
Luminous flux in emergency operation mode	480 lm
Luminous flux in maintained operation mode	4000 lm

Light technical data

Beam angle	70 °
------------	------

UGR lateral	<16
UGR longitudinal	<16

Dimensions & weight

Length	595.0 mm
Width	595.0 mm
Height	13.0 mm
Product weight	3700.00 g
Mounting width	575.0 mm
Mounting length	575.0 mm

Colors & materials

Product color	White
Housing color	White
Body material	Steel
Light emitting surface material	Polycarbonate

Temperatures & operating conditions

Ambient temperature range	+5...+40 °C
----------------------------------	-------------

Lifespan

Number of switching cycles	25000
Lifespan L70/B50 at 25 °C	80000 h
Lifespan L80/B10 at 25 °C	60000 h
Lifespan L90/B10 at 25 °C	35000 h

Additional product data

Mounting type	Recessed
Mounting location	Ceiling
Low flicker	Yes
Type of Battery	LiFePO4

Capabilities

Dimmable	No
Type of connection	Screw terminal, 2-POLE (N, L, L switchable)
Type of emergency operation test	Automatic
Battery life in emergency operation mode	3 h
Battery charging time	<24 h
Area of emergency application	Anti-panic lighting / Escape route lighting
Type of emergency light operation	Maintained / Non-maintained

Integrated test switch	No
LED module replaceable	Not replaceable

Certificates & standards

Type of protection	IP40
Protection class	II
Protection class IK (shock resistance)	IK08
Glow Wire Test according to IEC 60695-2-12	850 °C
Photobiological safety group EN62778	RG 1
Standards	CE/CB/EAC/RoHS

Logistical data

Temperature range at storage	5...+35 °C
-------------------------------------	------------

Light Distribution

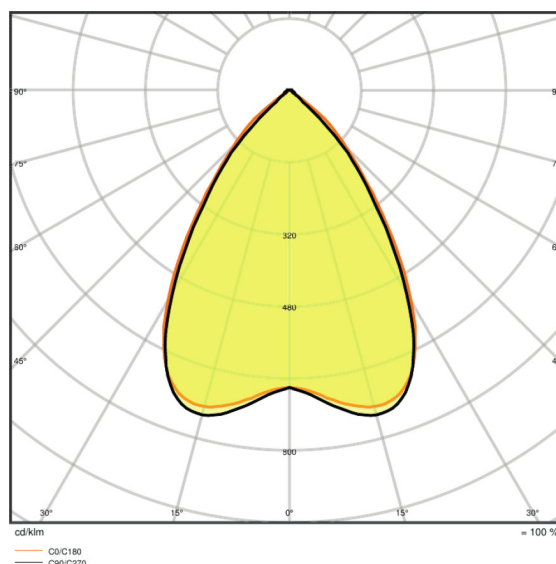
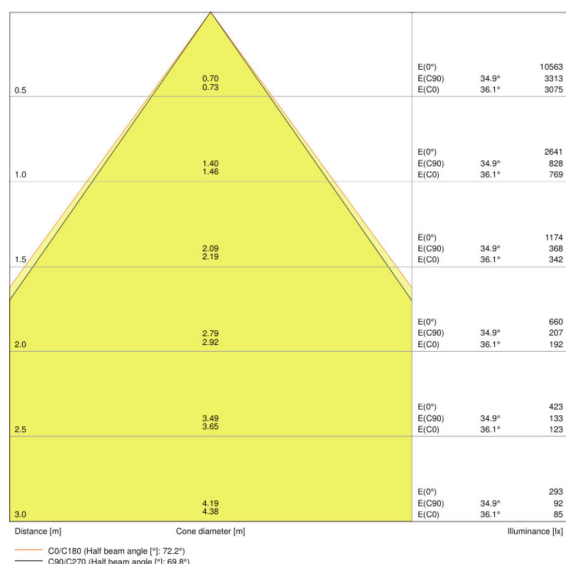

LDC typ cone

LDC typ polar

EQUIPMENT / ACCESSORIES

- Optional mounting clips available
- Security rope for luminaire included
- External control gear included
- Control LED with a holder for recessed installation included

LOGISTICAL DATA

Product code	Packaging unit (Pieces/Unit)	Dimensions (length x width x height)	Gross weight	Volume
4058075201316	Folding carton box 1	646 mm x 48 mm x 737 mm	4215.00 g	22.85 dm ³
4058075201323	Shipping carton box 4	750 mm x 210 mm x 658 mm	17615.00 g	103.64 dm ³

The mentioned product code describes the smallest quantity unit which can be ordered. One shipping unit can contain one or more single products. When placing an order, for the quantity please enter single or multiples of a shipping unit.

ADDITIONAL CATALOG INFORMATION

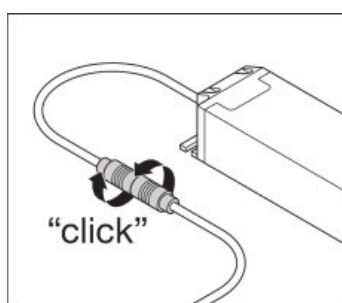
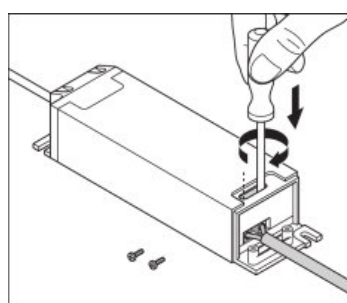

REFERENCES / LINKS

For Guarantee see

▶ www.ledvance.com/guarantee

DISCLAIMER

Subject to change without notice. Errors and omission excepted. Always make sure to use the most recent release.